



**SaniServ**<sup>®</sup>  
An AFFINIS GROUP Company

Item No. \_\_\_\_\_  
Quantity \_\_\_\_\_  
Job Name \_\_\_\_\_

**Designed for High Volume Operations**  
**8 Gallons Per Hour - 20 Quart Capacity**

## **Model 707**

Countertop  
Frozen Beverage Machine

The **SaniServ** Model 707 Frozen Beverage Machine is a customer favorite! Its sleek single barrel profile has the ability to offer many types of slush beverages! Choose from frozen margaritas and daiquiris to frozen fruit flavor drinks such as frozen lemonade and fruit smoothies. The 707 is a must have for the customer looking for an affordable way to offer all of their favorite beverages frozen!

### **Space Saving plus Consistent**

**Small Footprint Design** - Save valuable floor space and turn the bar or countertop into a real profit center. By offering the finest quality of frozen drinks each time, every frozen beverage is consistent from the first to the last!

### **Easy Cleaning and Operation**

**Fewer Parts = Simplified Cleaning** – **SaniServ** equipment is designed and built with the fewer parts to be disassembled, cleaned and sanitized than any other machine in the industry.

### **High Return on Investment**

**Increased Profits** – **SaniServ** machines combine affordable efficiency with consistent product quality and fast quiet operation to insure customer satisfaction with high profit frozen beverages.

### **Quality Design**

**Durability** – **SaniServ** machines are built to achieve long and dependable life through simplicity of design. Every machine is shipped standard with a stainless steel exterior, durable steel interior frame construction, heavy-duty components and consistency systems.



Made in the USA

# Model 707A

## Counter Model Frozen Beverage/Cocktail Freezer

For sales information contact:

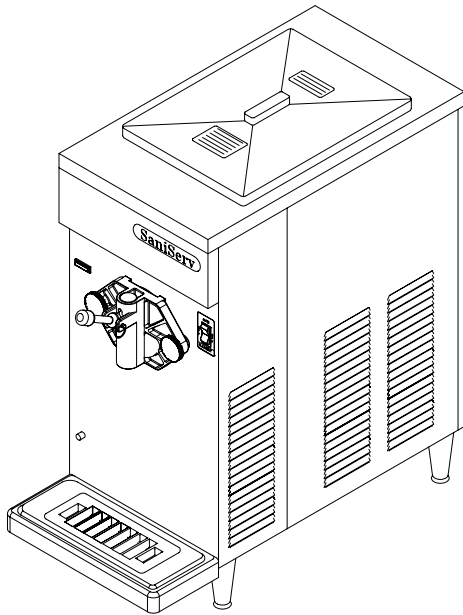

Minimum Wall Clearance 6" (152mm) - Both Sides and Back

Note: This unit must be installed on legs with 4" (102mm) minimum clearance beneath it for proper air circulation.

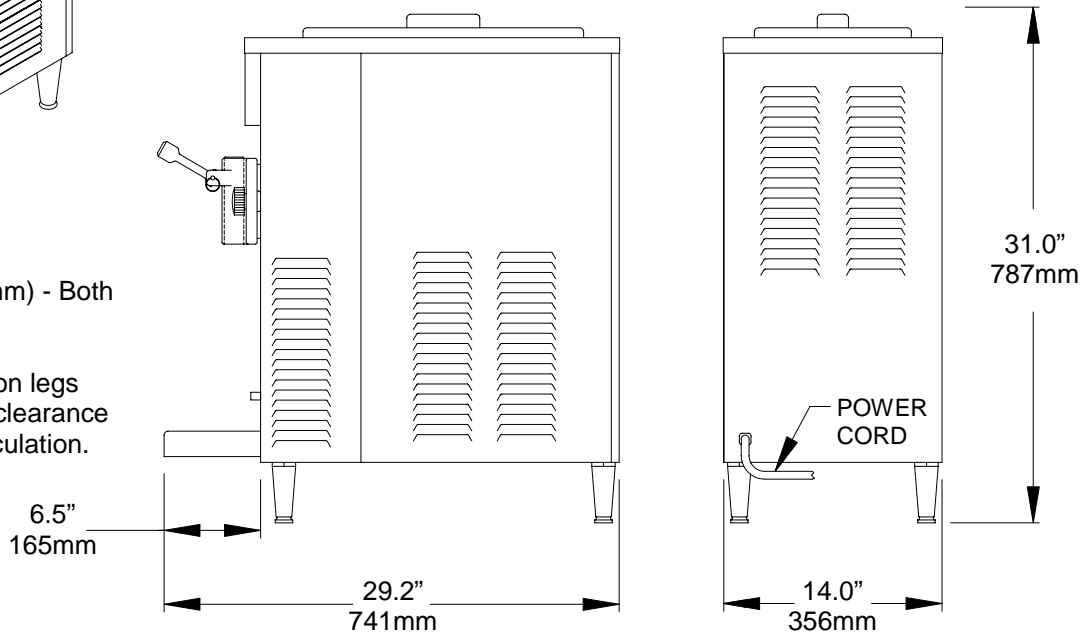

	WIDTH INCHES (mm)	HEIGHT INCHES (mm)	DEPTH INCHES (mm)	WEIGHT LBS (kg)	VOLTS	HZ	PHASE	AMPS
MACHINE	14.0 (356)	31.0 (787)	29.2 (741)	159 (72)	115	60	1	11.5
MACHINE CRATED	22.5 (572)	38.0 (965)	34.5 (876)	189 (86)				

**Quick Recovery...**  
**Compact and Durable...**  
**Simple in design for easy cleaning...**  
**Heavy duty components...**

**Standard Electrical:**  
 115/60 Hz/1Ø/11.5 Amp  
 Cord and plug attached

**Controls:** Automatic consistency controls for improved product consistency.

**Solid State Automatic Audio and Visual Mix Out Alert System** for the protection of your investment.

**Evaporator and Mix Reservoir**

**Capacity:** 20 Qrts (18.9 ltrs)

**Construction:** Stainless Steel Exterior, Legs Required.

**Dasher:** Heavy-Duty Stainless Steel with low friction scraper blades.

**Dasher and Compressor Motors:**  
 1/2 HP Dasher 1/2 HP Compressor

**Shipping Volume:** 18.06 ft<sup>3</sup> (0.51 m<sup>3</sup>)

**Refrigerant Type:** R404A

**Listings:** UL, cUL, NSF

**Warranty:**

Parts 1 year  
 Compressor 5 years

**Equipment Options:**

Wash Out Kit - 3/8" (9.525 mm) Flare Fittings  
 Tune Up Kit  
 Drink Spinner  
 Parts Tray  
 50 Hz Voltages Available  
 Stand - Welded Stainless Steel Construction

We reserve the right to change specifications and product design without notice. Such revisions do not entitle the buyer to corresponding changes, improvements, additions or replacements for previously purchased equipment.